



F&B RUBBERIZED, INC.

37 WASHBURN STREET

NEW BEDFORD, MA 02740

CALL: (508) 999-4124 - FAX: (508) 997-0649

Recycled Product

100% of the rubber in each unit is Recycled OTR, Truck, Bus, Radial and Bias Ply tires.

Durable

The rubber sections are compressed onto 1" steel rods which are Welded Solid, instead of Nuts that can hang up and Rip-off the End Plates. The plates are secured the first 4" and then every 12" throughout the unit with flat bar retaining plates with complete welds.

Installation

The Slide- Channel allows the Installer to adjust the 3 x 3 1/2 x 3/4" washers and Grade-8 Plow Bolts into position to line up with the Existing Bolt Holes.

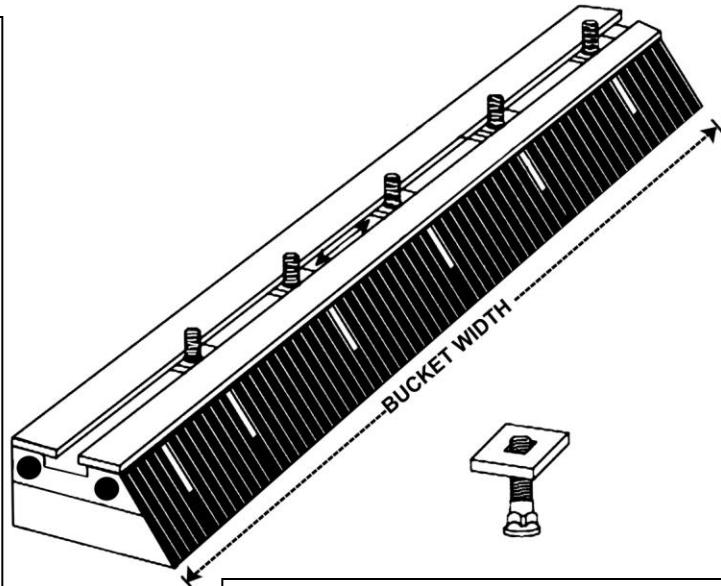

Wear & Cost

Our Edges will last as long as or longer than any Competitor at Substantial Savings.

GUARANTEED

SBR-10

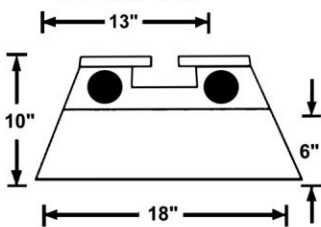

Our **SBR-10** can be used for Pushing, Back Blading and occasional Loading. It is beveled on each side so it can be reversed if necessary. We offer these Edges in Bias Ply and Radial. The Bias Ply Edge is used to Eliminate **Sparking**.

SB-10

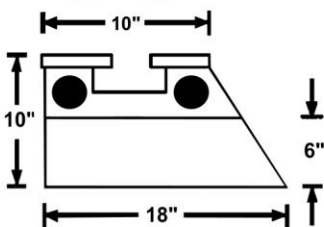

Our **SB-10** profile is for applications where Loading is more critical than Pushing. This model has more of a bevel than the SBR-10. These Edges come in Bias Ply and Radial. The Bias Ply Edge is used to Eliminate **Sparking**.

mikem@fbrubberized.com

SB-6

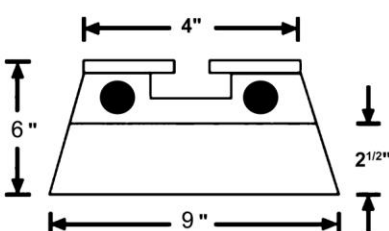

Our **SB-6** is ideal for Skid Steers and small Loaders in Recycling Plants. Beveled on both sides this Edge is reversible. We can accommodate any bucket width. This edge has 9" of surface wear and 2 1/2" depth wear. Most sizes in stock.

The SB-6 Edge is made of Bias Ply to Eliminate **Sparking**.

www.fbrubberized.com